

NORTHERN LIGHTS

M864W3

Service Side

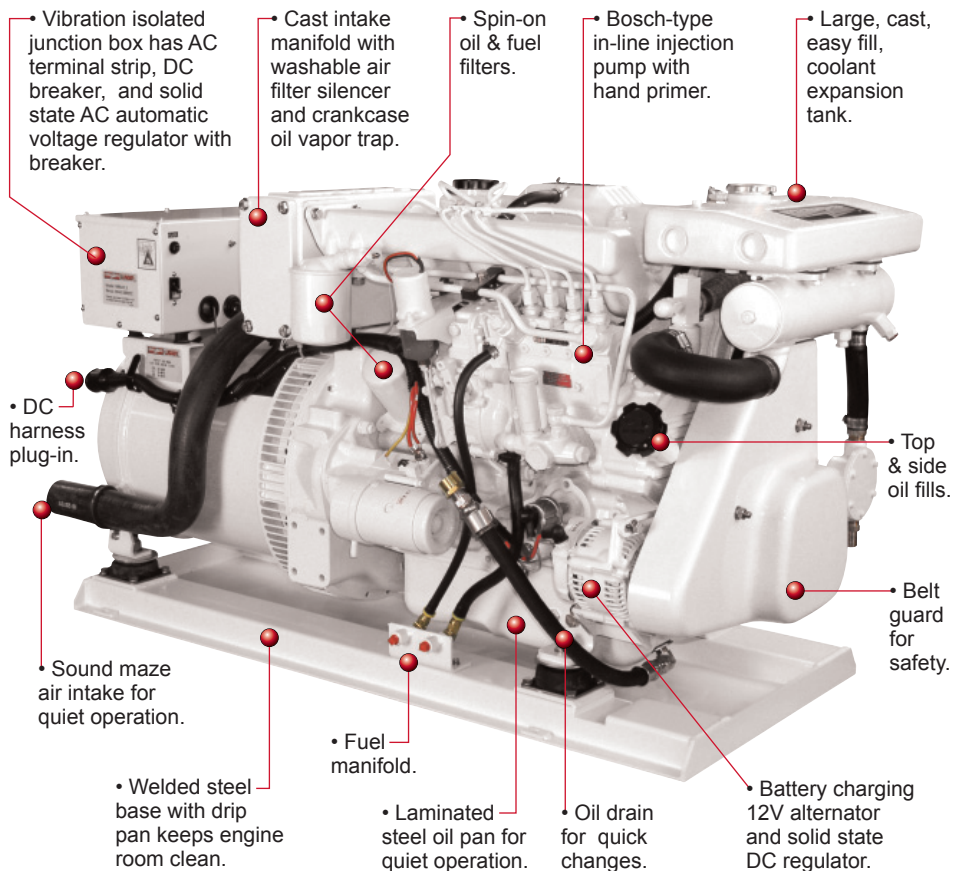

Non-Service Side

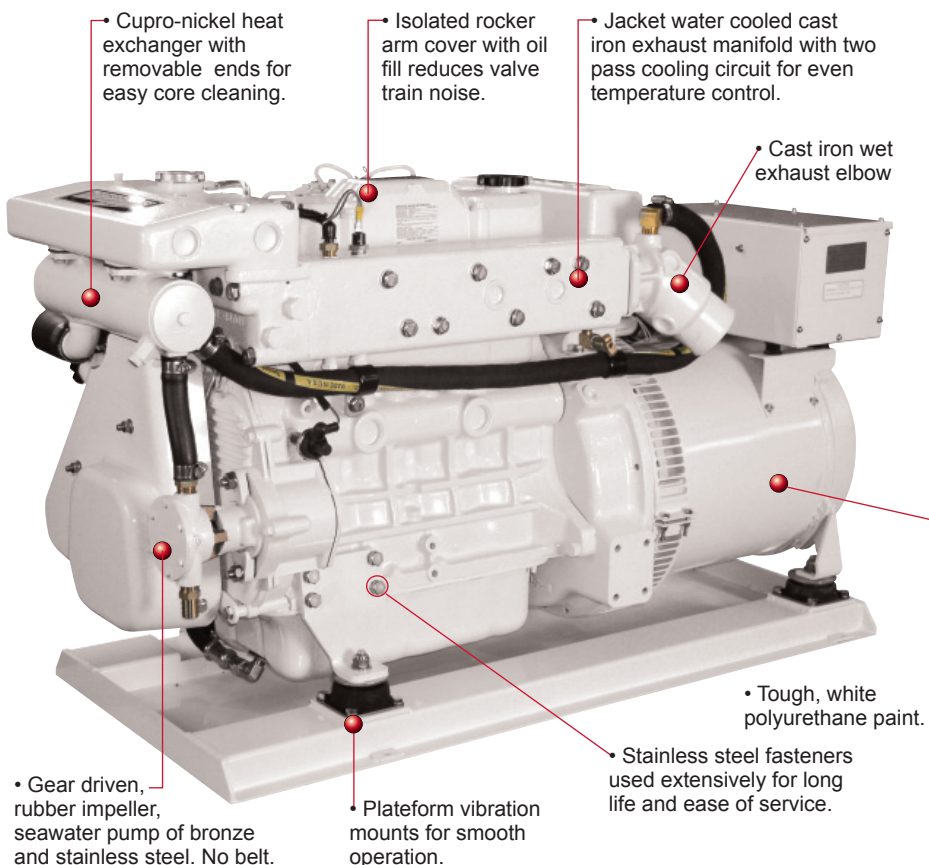

25 kW
60 Hz / 1800 RPM

20 kW
50 Hz / 1500 RPM

The M864W3 combines ample power, long life features, and low emissions owners expect from a Northern Lights.

Exceptionally smooth, quiet and clean, it makes life aboard comfortable while protecting the environment. The 2.5 liter Luger diesel has been designed for clean exhaust and meets the US EPA Tier III emission requirements.



Noise is reduced at the design stage with several features. A laminated oil pan and an isolated rocker arm cover contain the noise at its source. A noise maze air intake silencer lowers noise while isolation mounts limit transmission of vibration to the vessel. For even more comfort specify a super attenuated, powder coated sound enclosure.

The M864W3 is easy to live with and to service. Single side servicing, spin-on oil and fuel filters, washable air filter, two oil fills and a sea water pump you can actually reach make it a skipper's dream. The relay based DC electrical system has no printed circuit board so you'll never have to make the "motherboard" of all parts purchases.

The M864W3 is available with a front PTO (power take off) and electric clutch. With the touch of a button you have up to 37 Horsepower at 1800 rpm for powering hydraulic accessories such as bow thrusters, roller furling, anchor winches and deck gear.

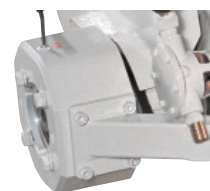

Front PTO

Featuring new W-Series generator

The new W-Series generator end is a major step in our constant quest to give you the best generator set on the market. It features an auxiliary stator winding that supplies separate and stable power to the Automatic Voltage Regulator (AVR). The results are impressive:

- Classification society compliance.
- Real 300% short circuit capability.
- Improved AC circuit breaker performance.

See your dealer for more information.



AC Output ¹	
25 kW	60 Hz, 1800 RPM, 1 Ph, 1.0 PF, 120-240 V/104 A, 120 V/208 A
20 kW	50 Hz, 1500 RPM, 1 Ph, 1.0 PF, 220 V/90.9 A
Optional	Three Phase with 0.8 PF
Voltage regulation	±1%

Lugger L864 Engine	
Type	Vertical inline 4 cylinder diesel
Displacement	152 in ³ (2.49 ltr)
Bore/Stroke	3.4/4.2 in (86/107 mm)
HP @ RPM	39.4/1800 33.0/1500
Approx. fuel use	
1800 RPM @ full load ²	2.23 gph (8.4 lph)
1800 RPM @ half load ²	1.17 gph (4.4 lph)
1500 RPM @ full load ²	1.78 gph (6.73 lph)
1500 RPM @ half load ²	0.93 gph (3.52 lph)

Installation Data & Weight	
Wet exhaust elbow	3 inch (76 mm) OD
Raw water inlet	3/4 inch (19 mm) OD
Fuel inlet and return	1/4 inch NPT
Approximate dry weight	993 lbs (450 kg)

1. Based on SAE J1995 and ISO 3046. 2. Actual fuel consumption will vary depending on operating conditions

M864W3 Dimensional Drawing

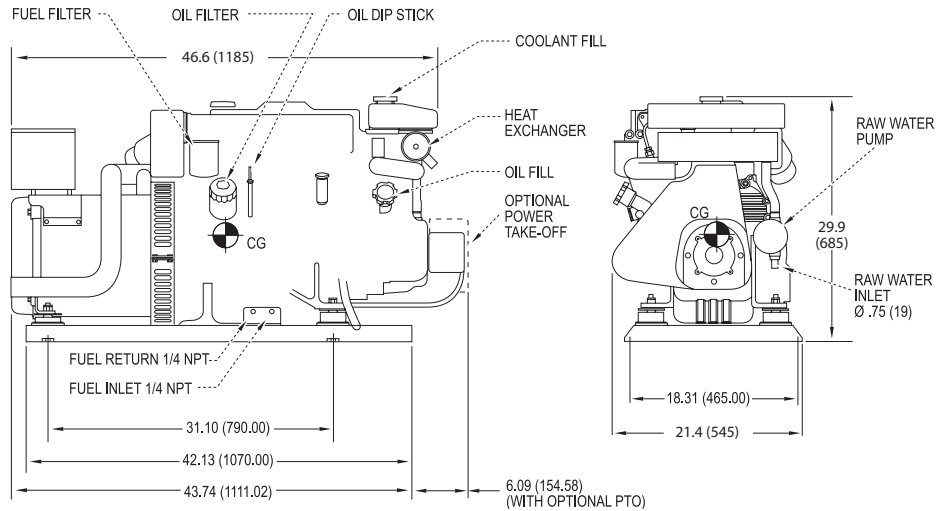

Overall Dimensions L x W x H: 46.6 x 21.4 x 26.7 inch (1185 x 545 x 678 mm)
 Dimensions given in inches (mm). Dimensions subject to change without notice.
 Contact dealer or visit www.northern-lights.com for most current installation drawings.

M864W3 Features and Benefits

Engine Block

- Lugger, four cycle, 4 cylinder, liquid cooled, naturally aspirated, overhead valve diesel engine.
- Crankshaft is induction hardened, forged carbon steel; stronger than cast iron.
- Helical cut and ground, carbon steel timing and PTO gears reduce noise.
- Cross flow head for efficient breathing.
- Laminated steel oil pan reduces noise.
- Glow plugs for quick cold starts.

Cooling System

- Freshwater cooling system in heat exchanger or keel cooled configuration.
- Large, easy fill expansion tank.
- Cast iron exhaust manifold is freshwater cooled for safety. No hot, dry risers.
- Zinc anode electrolysis protection.
- Heat exchanger cooling: Easy to clean, cupronickel tube-type heat exchanger. Gear driven, rubber impeller seawater pump of bronze and stainless steel requires no drive belts.

Fuel System

- Fuel system is self-venting.
- Bosch-type in-line injection pump with 5% mechanical governor for close AC output frequency control.
- Pintle-type injectors. Replaceable tips.
- Mechanical fuel lift pump w/ hand primer.
- Large spin-on fuel filter.
- Flexible fuel lines routed to base.
- Stop solenoid controls fuel rack, not throttle, for quick engine shutdowns.

Intake and Exhaust

- Meets US EPA Tier III emissions.
- Washable air cleaner in cast intake manifold reduces intake noise.
- Cast iron, wet exhaust elbow for safety.
- Oil vapor trap for cleaner engine room

Lubrication System

- Full flow, spin-on oil filter with bypass.
- 6.9 qt. (6.5 ltr) oil capacity for better lubrication. 200 hr oil change intervals.
- Oil drain for quick, clean oil changes.

DC Electrical System

- DC system uses reliable relays instead of unrepairable printed circuit board.
- 12 volt starter motor and battery charging alternator with regulator and belt guard.
- Standard panel: Remote mount S-3C has hour meter and gauges for oil pressure, coolant temp, and DC volts. Stop-start switch and preheat switch.
- Expandable to six panels 110 ft from set.
- 20 foot (6 m) plug-in panel harness lets you mount your panel anywhere onboard.
- Low oil pressure, high coolant and high exhaust temperature safety shutdowns.



AC Generator

- Northern Lights, direct coupled, brushless AC generator is maintenance free. 4 lead-1 phase 50 or 60 Hz output standard. 12 lead-3 phase optional. Conservative heat rise rating: 95°C/50°C ambient.



- Automatic Voltage Regulator is powered by dedicated AC winding for true 300% short circuit capability. AVR gives quick ±1% RMS no load to full load voltage regulation. AVR is circuit breaker protected.
- Generator has high quality epoxy Class "H" insulation, accessible diodes, oversized bearing and junction box for AC wiring.

Special Equipment

- Welded steel base frame with drip pan.
- Four platform mounts isolate vibration.
- White, long-life polyurethane paint.
- Operator's and parts manuals standard.

Classification

Standards

- Contact factory for details.



Optional Equipment

- See accessory brochure for a complete list of customizing equipment.
- **Front PTO:** B-spline, 2 or 4 bolt front power take-off with 12 or 24 volt electric clutch. Take up to 37 HP @ 1800 rpm to run your bow thruster, sail handling, deck winches and other hydraulic equipment.
- Sound enclosure has powder coated marine aluminum panels lined with sound barrier foam to dampen noise. Trigger latches for easy access.



LxWxH: 53.15 x 27.38 x 28.91 in
 (1350 x 695.4 x 734.3 mm)
 Weight: 140 lbs (63.5 kg)

Dealer

4420 14th Ave. NW., Seattle WA 98107
 Tel: (206) 789-3880 • 1-800-762-0165 • Fax: (206) 782-5455
 Information and dimensions subject to change without notice.
 Northern Lights and Lugger are registered trademarks
 of Northern Lights, Inc.
 © 2009 All rights reserved. Litho USA. L719 3/11



www.northern-lights.com