

ZF W43000 NC

Vertical offset, remote mount marine transmission.

Description

- Marine reduction transmission series for heavy duty, commercial application comprising:NC:Direct Drive Reduction (without clutch) .
- Robust design also withstands continuous duty in workboat applications .
- Fully works tested, reliable and simple to install .
- Compatible with all types of engines and propulsion systems .
- Design, manufacture and quality control standards comply with ISO 9001 .
- Easy onboard maintenance .

Features

- Robust, torsion - resistant housing (cast iron/welded steel) .
- Case hardened and precisely ground gear teeth for long life and smooth running .
- Output shaft thrust bearing designed to take maximum propeller thrust .
- Free standing .
- Cast-on brackets .
- Oil cooler complete with fittings .

Options

- Engine-matched torsional coupling .
- Standard monitoring system .
- Special monitoring (acc. Classification Society requirements) .
- Propeller shaft flange and coupling bolt sets .
- PTO (live or clutchable) .
- Standby oil pump .
- Classification by all major Classification Societies on request .

ZF W43000 NC

Ratings

Continuous Duty

RATIOS	MAX. TORQUE		POWER/RPM		INPUT POWER CAPACITY						MAX. RPM
	Nm	ftlb	kW	hp	600 rpm		750 rpm		1000 rpm		
					kW	hp	kW	hp	kW	hp	
2.536	53767	39657	5.6301	7.5500	3378	4530	4223	5663	5630	7550	1000
2.960	48419	35712	5.0701	6.7991	3042	4079	3803	5099	5070	6799	1000
3.667	37723	27823	3.9501	5.2971	2370	3178	2963	3973	3950	5297	1000
3.714	36863	27189	3.8600	5.1763	2316	3106	2895	3882	3860	5176	1000
3.950	33158	24456	3.4720	4.6561	2083	2794	2604	3492	3472	4656	1000
4.409	26320	19413	2.7560	3.6959	1654	2218	2067	2772	2756	3696	1000

* Special Order Ratio.

Ratings shown for the ZF W17000, and larger gearboxes, are valid for applications without ice classification and comply with BV (Bureau Veritas) rules.

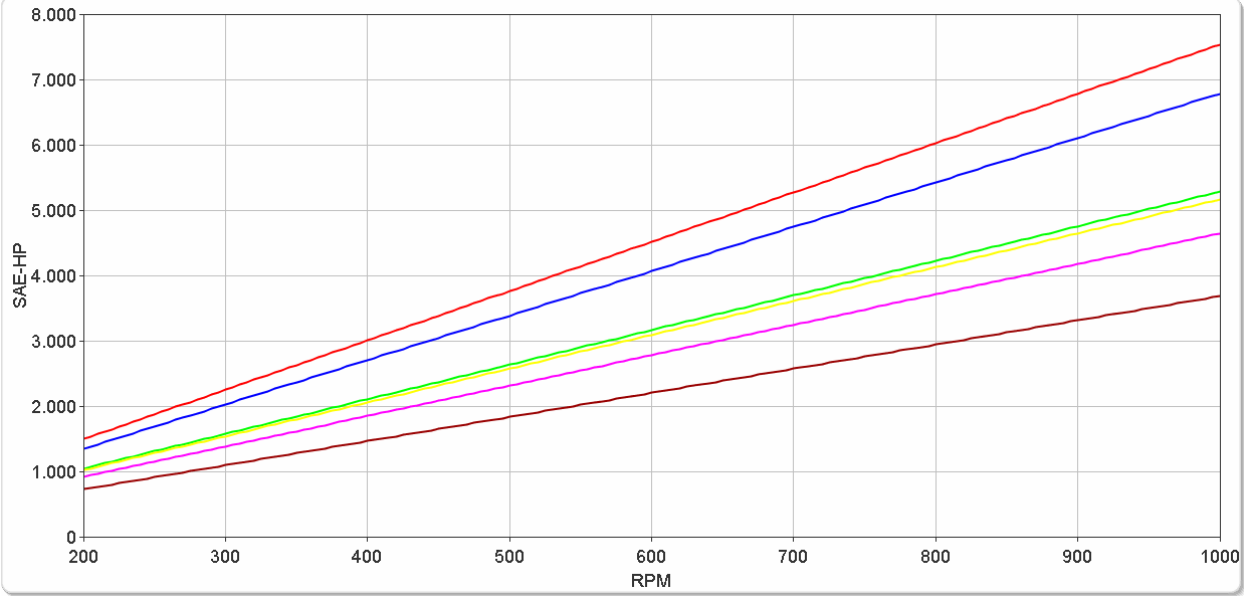
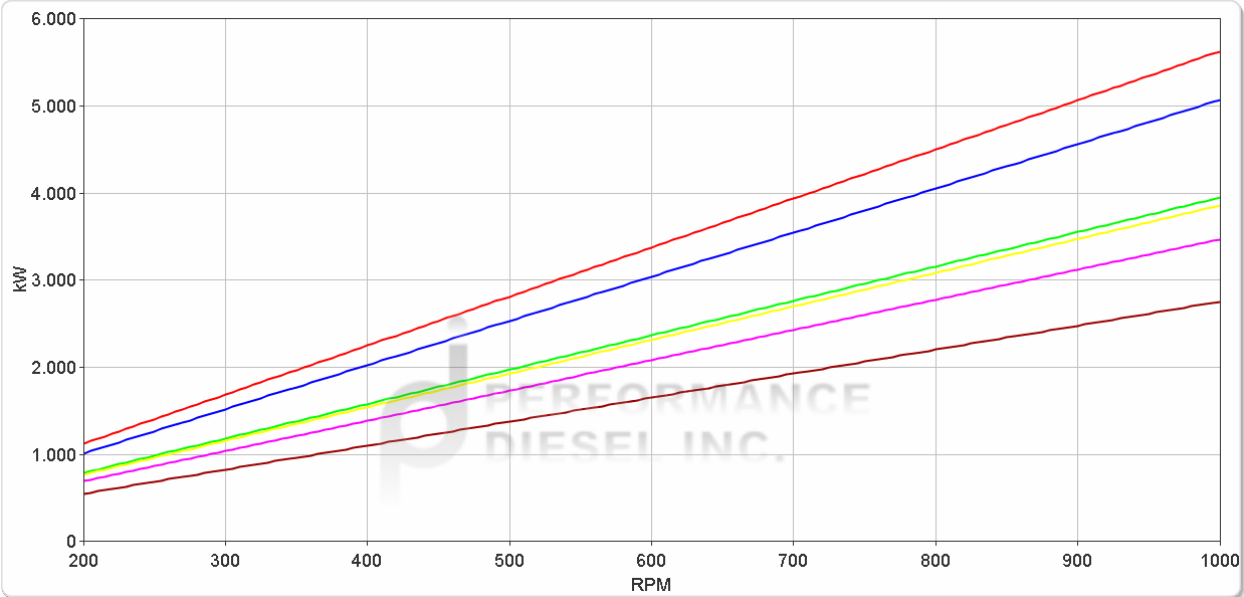

ZF W43000 NC

Dimensions

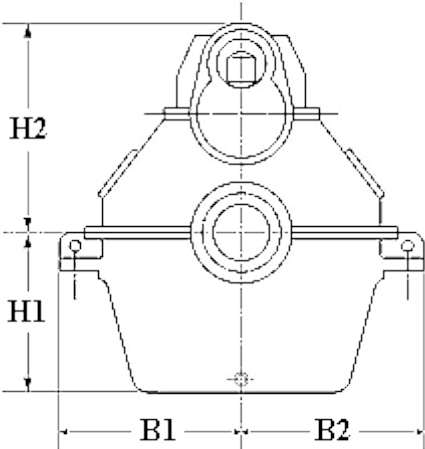
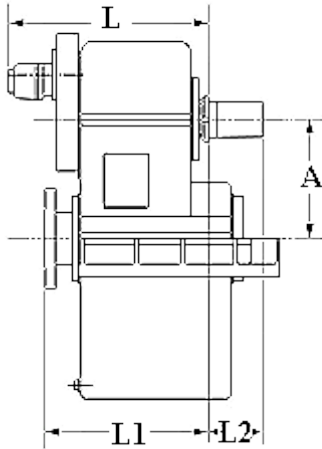

mm (inches)							
A	B ₁	B ₂	H ₁	H ₂	L	L ₁	L ₂
600 (23.6)	860 (33.9)	860 (33.9)	800 (31.5)	1,255 (49.4)	1,100 (43.3)	930 (36.6)	340 (13.4)
Weight kg (lb)				Oil Capacity Litre (US qt)			
5,400 (11,880)				280 (297)			

Output Coupling Dimensions

A		B		C		D		Bolt Holes No.	Bolt Holes Diameter (E)	
mm	in	mm	in	mm	in	mm	in		mm	in
600	23.6	530	20.9	340	13.4	56.0	2.20	12	37.0	1.46

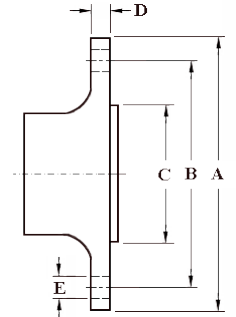

ZF W43000 NC

PTO

PTO Configurations

PTO3 (Live)

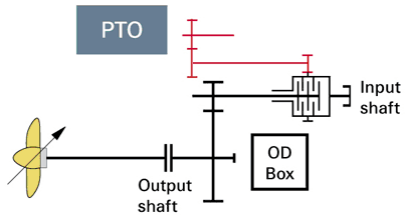

PTO4 (Clutchable)

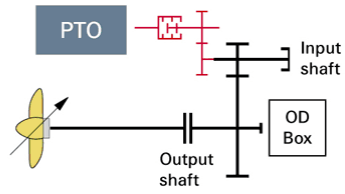

PTO5 (Live)

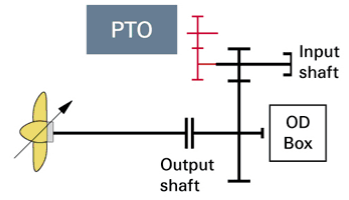

Duty Definitions

CONTINUOUS DUTY DEFINITION Continuous operation with little or no variations in engine speed and power

Average engine operating hours limit: **Unlimited**

Typical hull forms: **Displacement.**

Typical applications: **Heavy duty commercial vessels, tugs, fishing boats.**

Duty Ratings

Ratings apply to marine diesel engines at the indicated speeds. At other engine speeds, the respective power capacity (kW) of the transmission can be obtained by multiplying the Power/Speed ratio by the speed.

Approximate conversion factors:

1 kW = 1.36 metric hp

1 kW = 1.34 U.S. hp (SAE)

1 U.S. hp = 1.014 metric hp

1 Nm = 0.74 lb.ft.

Ratings apply to right hand turning engines, i.e. engines having counterclockwise rotating flywheels when viewing the flywheel end of the engine. These ratings allow full power through forward and reverse gear trains, unless otherwise stated.

Contact your nearest ZF Sales and Service office for ratings applicable to gas turbines, gasoline (petrol) engines, as well as left hand turning engines, and marine transmissions for large horsepower capacity engines.

Ratings apply to marine transmissions currently in production or in development and are subject to change without prior notice.

NOTE: THE MAXIMUM RATED INPUT POWER MUST NOT BE EXCEEDED (SEE RESPECTIVE RATINGS IN THE TECHNICAL DATA SHEETS)

Safe Operating Notice

The safe operation of ZF products depends upon adherence to technical data presented in our brochures. Safe operation also depends upon proper installation, operation and routine maintenance and inspection under prevailing conditions and recommendations set forth by ZF. Damage to transmission caused by repeated or continuous emergency manoeuvres or abnormal operation is not covered under warranty. It is the responsibility of users and not ZF to provide and install guards and safety devices, which may be required by recognized safety standards of the respective country (e.g. for U.S.A. the Occupational Safety Act of 1970 and its subsequent provisions).

Monitoring Notice

The safe operation of ZF products depends upon adherence to ZF monitoring recommendations presented in our operating manuals, etc. It is the responsibility of users and not ZF to provide and install monitoring devices and safety interlock systems as may be deemed prudent by ZF. Consult ZF for details and recommendations.

Torsional Responsibility and Torsional Couplings

The responsibility for ensuring torsional compatibility rests with the assembler of the drive and driven equipment. ZF can accept no liability for gearbox noise caused by vibrations or for damage to the gearbox, the flexible coupling or to other parts of the drive unit caused by this kind of vibration.

Contact ZF for further information and assistance. ZF recommends the use of a torsional limit stop for single engine powered boats, wherein loss of propulsion power can result in loss of control. It is the buyer's responsibility to specify this option, which can result in additional cost and a possible increase in installation length.

ZF can accept no liability for personal injury, loss of life, or damage or loss of property due to the failure of the buyer to specify a torsional limit stop. ZF selects torsional couplings on the basis of nominal input torque ratings and commonly accepted rated engine governed speeds. Consult ZF for details concerning speed limits of standard offering torsional couplings, which can be less than the transmission limit. Special torsional couplings may be required for Survey Society Ice Classification requirements.